

TYPICAL BRANCH DUCT CONNECTION DETAIL
 SCALE: NONE

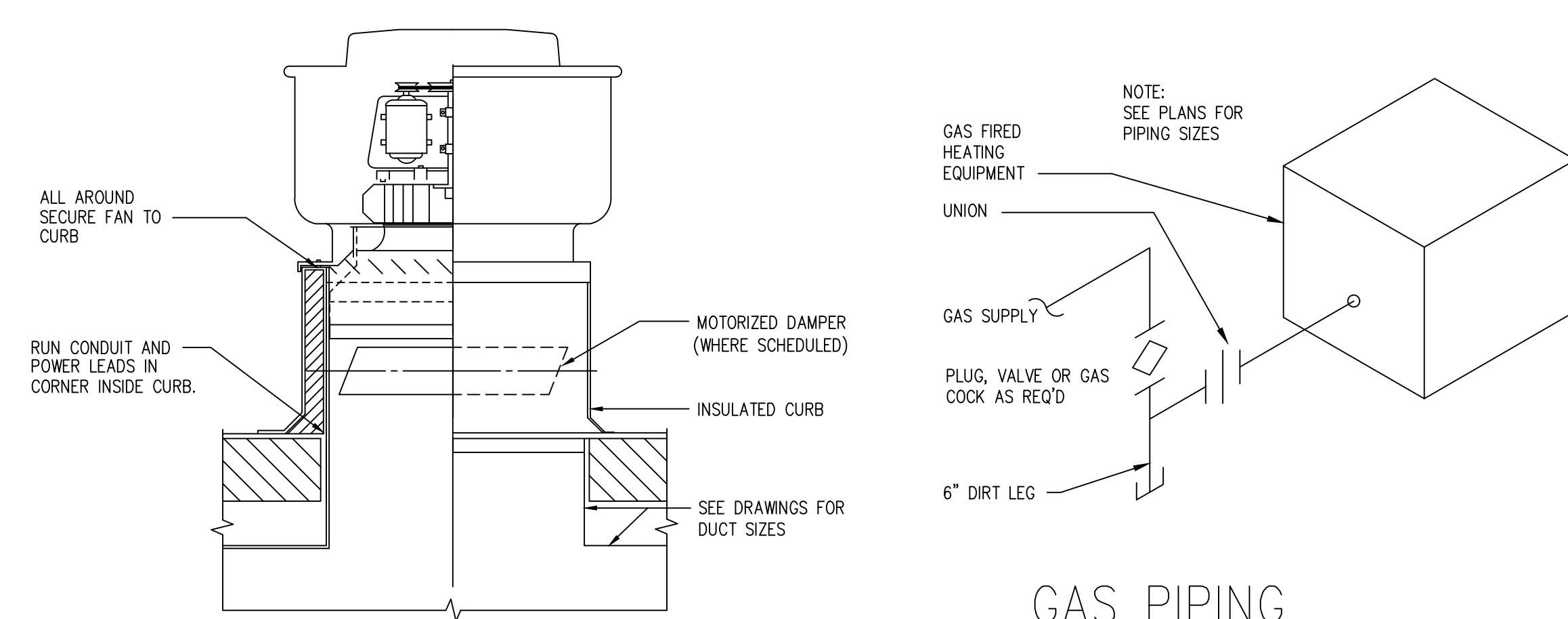

POWER ROOF VENTILATOR DETAIL
 SCALE: NONE

GAS PIPING CONNECTION DETAIL
 SCALE: NONE

EXHAUST FAN SEQUENCE OF CONTROL

- EF-1: EXHAUST FAN WILL START WHEN TOILET ROOM LIGHT SWITCH IS TURNED ON. 20 MINUTE (ADJUSTABLE) TIMER WILL START WHEN LIGHT SWITCH IS SHUT OFF. AT THE END OF 20 MINUTES (ADJUSTABLE) EXHAUST FAN WILL TURN OFF. IF TOILET ROOM LIGHT SWITCH IS TURNED ON BEFORE TIMER REACHES SHUT OFF TIME THE TIMER WILL BE RESET TO 20 MINUTES (ADJUSTABLE).
- EF-2: EXHAUST FAN WILL START WHEN LIGHT SWITCH IN EITHER TOILET ROOM IS TURNED ON. 20 MINUTE (ADJUSTABLE) TIMER WILL START WHEN BOTH LIGHT SWITCHES ARE SHUT OFF. AT THE END OF 20 MINUTES (ADJUSTABLE) EXHAUST FAN WILL TURN OFF. IF LIGHT SWITCH IN EITHER TOILET ROOM IS TURNED ON BEFORE TIMER REACHES SHUT OFF TIME THE TIMER WILL BE RESET TO 20 MINUTES (ADJUSTABLE).

Furnace Schedule										
Tag	Serves	Manufacturer	Model	Outside Air (cfm)	Airflow (cfm)	Input (mbh)	Output (mbh)	Circuit Amps	Voltage	Remarks
F		Carrier	59TP6A060E171114	140	1210	60/39	58/38	14.5	115	Note 1

Note 1: Two Stage Furnace, provide filter cabinet with MERV 13 filter & 7 day thermostat with occupied/unoccupied settings

Furnace Evaporator Schedule					
Tag	Serves	Manufacturer	Model	Capacity (cfm)	Remarks
F		Carrier	CNPV3017ALA	1210	30

Condensing Unit Schedule									
Tag	Serves	Manufacturer	Model	Capacity (mbh)	Suction (in)	Liquid (in)	Circuit Amps	Voltage	Remarks
CU		Carrier	24ACC630A003	30	7/8	3/8	16.7	208/230-1	Note 1

Note 1: Provide Crankcase Heater

Grilles, Registers & Diffusers							
Tag	Manufacturer	Model	DP (in H2O)	Size (in) w x h	Neck size (in)	NC	Remarks
A	Krueger	1450	0.04	24x24	8	<10	
B	Krueger	1450	0.03	24x24	10	<10	
C	Krueger	1450	0.04	24x24	6	<10	
D	Krueger	1190	0.02	12x24	10x22	<10	
E	Krueger	6490	0.07	12x12	6x6	<10	

Fan Schedule									
Tag	Manufacturer	Model	CFM	ESP (in H2O)	HP	RPM	Voltage	dBA	Remarks
EF-1	Greenheck	SP-A110	100	0.15	14.1W	880	115	46	Note 1
EF-2	Greenheck	G-065-VG	200	0.2	1/10	1,556	115	46	Note 2

Note 1: Solid state speed control mounted on fan, hooded wall cap with round connection, time delay switch
 Note 2: ECM motor with speed control mounted under motor hood, 14 in High Curb, WD-100 Motorized Backdraft damper (115V).

Louvers						
Tag	Manufacturer	Model	Free Area Sq Ft	Size WxH (in)	Depth (in)	Remarks
OAL	Greenheck	ESJ-401	0.29	12x12	4	Note 1

Note 1: Aluminum Bird Screen, Baked Enamel Finish, Extended Sill

Electric Heater Schedule						
Tag	Manufacturer	Model	KW	Voltage	Amp Draw	Remarks
EWH	Qmark	CWH1151DSF	1.2	120	12.5	Integral thermostat
EBB	Qmark	CBD500	0.50	120	4.2	Integral thermostat

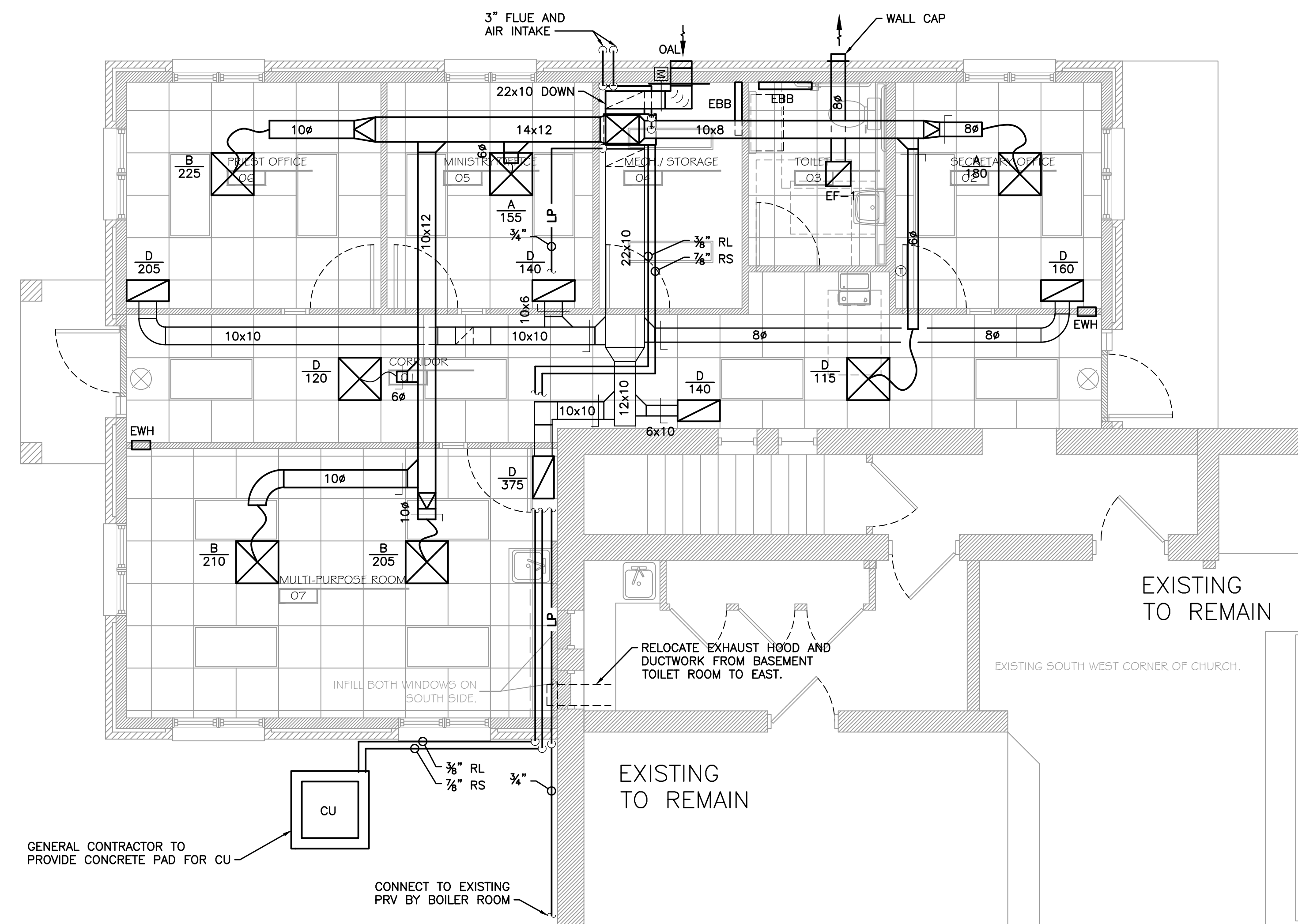

1 PARTIAL HVAC FLOOR PLAN NEW ADDITION
 M01 SCALE: 1/4" = 1'

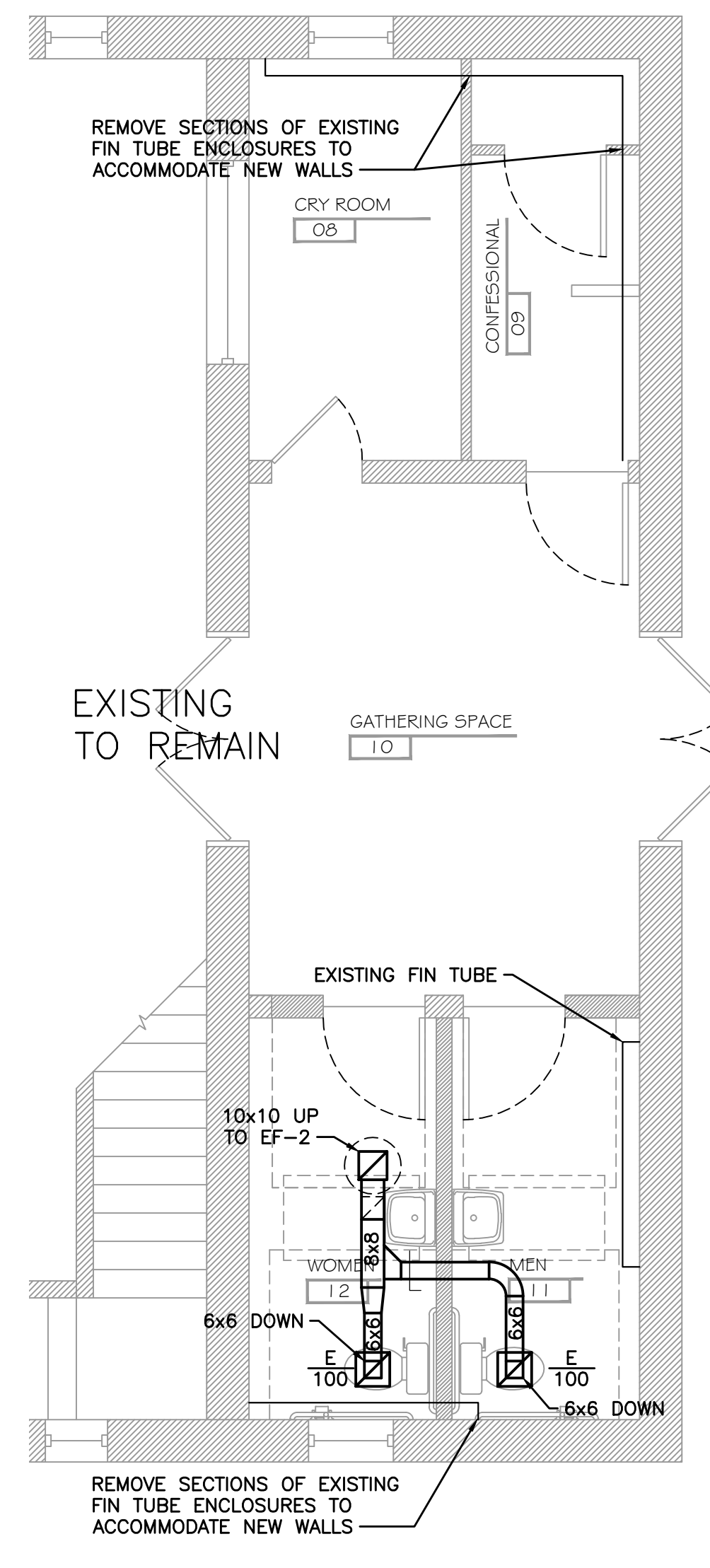

2 PARTIAL HVAC FLOOR PLAN
 M01 SCALE: 1/4" = 1'

DIMENSION IV
 Planning, Architectural Design, and Construction Administration
 Green Architecture and Sustainable Design
 124 S. Broadway, 1st Floor, Green Bay, WI 54301
 Phone: (920) 431-3444
 Fax: (920) 431-3445
 Email: info@dimensioniv.com

Facility Engineering Consultants
 Facility Engineering Consultants, LLC
 2301 Riverside Dr., Suite 13 Green Bay, WI 54301
 920-445-0430
 dean@facility-engineering.com

ST. ANTHONY PARISH
 ADDITION AND REMODEL
 W6799 CHURCH ST.
 NEOPT, WI

Verify all existing site conditions
 REVISIONS:
 NO. DATE
 SHEET INDEX:
 HVAC PLAN, NOTES AND SCHEDULES
 Copyright © 2014
 Idea House, Inc.
 DRAWN SN ✓ APPRVD DP
 June 13, 2016

M100
 STAnthony-M.dwg